

FLINTLOCK FLANGER V1.2

© 2014 lectric-fx

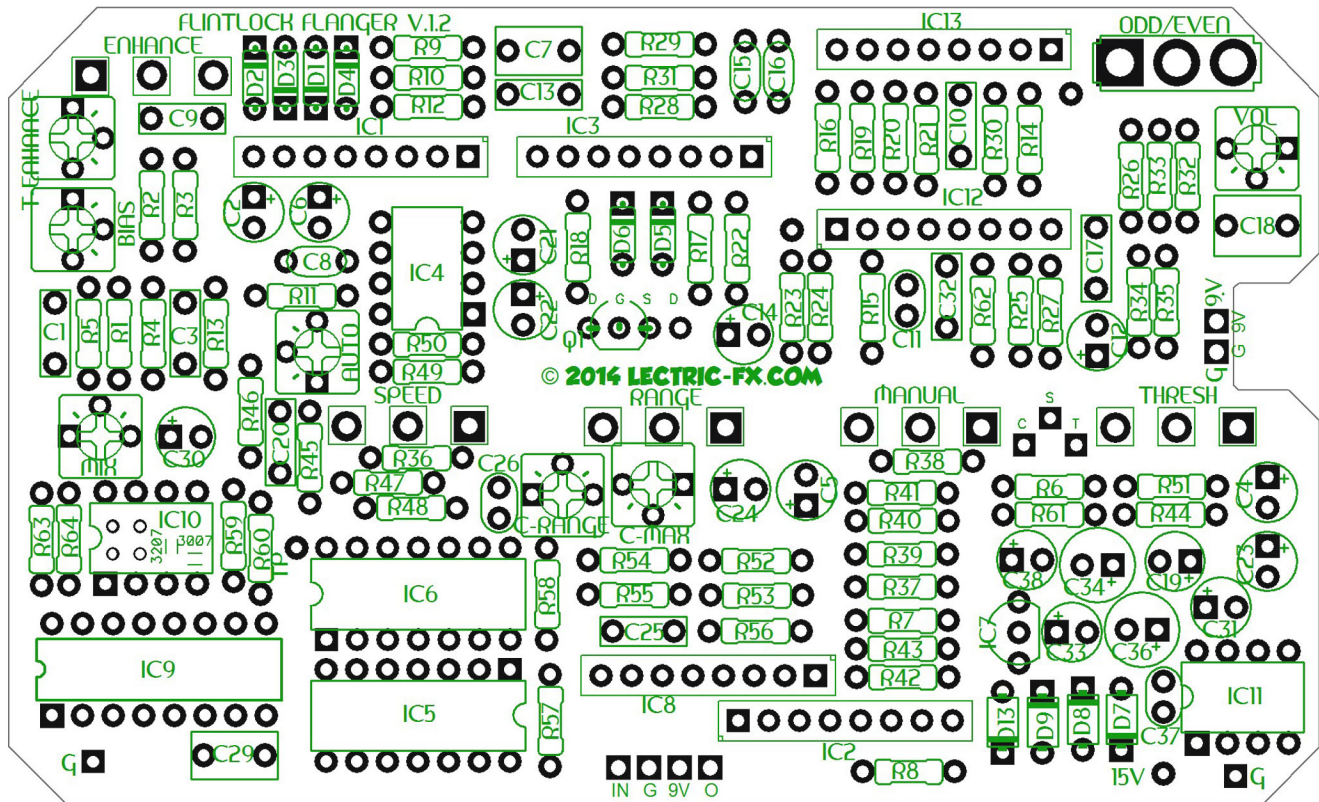

The Flintlock Flanger is a reproduction of the classic A/DA flanger circuit, adapted to use the more common MN3007 (Or MN/V/BL3207) BBD Chip, but still achieve the same sounds and wide sweep for which the original is famous. For the first time ever, this circuit can be built & housed in to a 1590BB enclosure if desired.

An on board charge pump & regulator is included to achieve the 15VDC voltage requirement for the circuit from a standard 9V supply, or to achieve a rock solid 9V for the 3207 version.

-CONTROLS:

- ENHANCE**- Increases the signal fed back in to the BBD for a more intense flange sound.
- SPEED**- Alters the rate of the sweep.
- RANGE**- Determines if the delay time is a function of the manual control, speed control or a blend of both.
- MANUAL**- Sets the delay time range, disabled when range is set fully clockwise.
- THRESHOLD**- A noise eliminating gate that cuts off the wet signal when the input signal is low, can also be used for 'dynamic' flanging. Function is minimized when set fully CW.
- ODD/EVEN**- Switch that sets the phase of the wet signal for Odd flanging (hollow pipe sound) or Even (full sound).

Bill of Materials

Part #	Value	Part #	Value	Part #	Value
R1	1k	C1	10n	Q1	2N5457
R2	30k	C2	4u7	Part #	Value
R3	2k7	C3	10n	RANGE	50KB
R4	30k	C4	22u	SPEED	500KC
R5	1M	C5	4u7	THRESH	100KB
R6	47r	C6	2u2	MANUAL	10KB
R7	68k	C7	470n	ENHANCE	10KB
R8	68k	C8	100p	Part #	Value
R9	20k	C9	100n	T-ENHANCE	20K
R10	27k	C10	10n	VOL	10K
R11	47k	C11	100p	AUTO	20K
R12	68k	C12	4u7	BIAS	20K
R13	10k	C13	100n	MIX	100K
R14	1k	C14	2u2	C-MAX	20K
R15	43k	C15	1n5	C-RANGE	100K
R16	100r	C16	510p		
R17	1M3	C17	10n		
R18	68k	C18	1u		
R19	100k	C19	22u		
R20	100k	C20	10n		
R21	22k	C21	33u		
R22	22k	C22	33u		
R23	10k	C23	22u		
R24	1M	C24	4u7		
R25	10k	C25	100n		
R26	10k	C26	22p		
R27	30k	C29	220n		
R28	22k	C30	4u7		
R29	68k	C31	22u		
R30	33k	C32	100n		
R31	33k	C33	10u		
R32	27k	C34	100u		
R33	5k1	C36	220u		
R34	100r	C37	*		
R35	100k	C38	10u		
R36	2k7	Part #	Value		
R37	100k				
R38	51k				
R39	100r	IC1	NJM4558L**		
R40	22k	IC2	NJM4558L		
R41	100k	IC3	NJM4558L		
R42	510k	IC4	LM1458 ***		
R43	1M	IC5	CD4007		
R44	47r	IC6	4047N		
R45	68k	IC7	7815L		
R46	82k	IC8	NJM4558L		
R47	100k	IC9	CD4049		
R48	75k	IC10	MN3007		
R49	1k	IC11	LT1054		
R50	2k7	IC12	NJM4558L		
R51	47r	IC13	NJM4558L		
R52	20k	Part #	Value		
R53	20k	D1	1n914		
R54	150k	D2	1n914		
R55	51k	D3	1n914		
R56	10k	D4	1n914		
R57	47r	D5	1n914		
R58	2M2	D6	1n914		
R59	2k	D7	1n4002		
R60	27k	D8	1n5817		
R61	270r	D9	1n5817		
R62	27k	D13	1n5817		
R63	2k7				
R64	2k7				

Shopping List

Resistor Value	Quant	Cap Value	Quant
47r	4	27p	1
100r	3	100p	2
270r	1	510p	1
1k	3	1n5	1
2k	1	10n	5
2k7	5	100n	4
5k1	1	220n	1
10k	5	470n	1
20k	3	1uF film	1
22k	4	2u2	2
27k	4	4u7	5
30k	3	10u	2
33k	2	22u	4
43k	1	33u	2
47k	1	100u	1
51k	2	220u	1
		Diode Value	Quant
68k	6	1n914	6
75k	1	1n4002	1
82k	1	1n5718	3
100k	6		
		Trans Value	Quant
150k	1	JFET	1
510k	1		
		Pot Value	Quant
1M	3	10KB	2
1M3	1	50KB	1
2M2	1		
		IC Value	Quant
		100KB	1
NJM4558L	6	500KC	1
		Trim Value	Quant
LM1458	1		
CD4047	1	10k	1 ****
CD4007	1	20k	4
MN3007	1	100k	2
LT1054	1		
CD4049	1		
78L15 TO-92	1		

You will also need to get some small jacks to fit this in a 1590BB I think. I have successfully fit mouser PN 550-10284. Enclosed jacks may also fit. Standard size jacks are untested.

- * OMIT unless there is undesirable noise between clock and charge pump. Try value 5p - 20p.
- ** You can most likely use any dual opamp in SIP-8 package for these 6. 4558L worked well for me.
- *** Any low power dual opamp should work well. TLO62, LM1458, LM358, etc.
- **** The pcb was designed to use 3362 cermet trimmers. Larger trimmer types might be a problem.

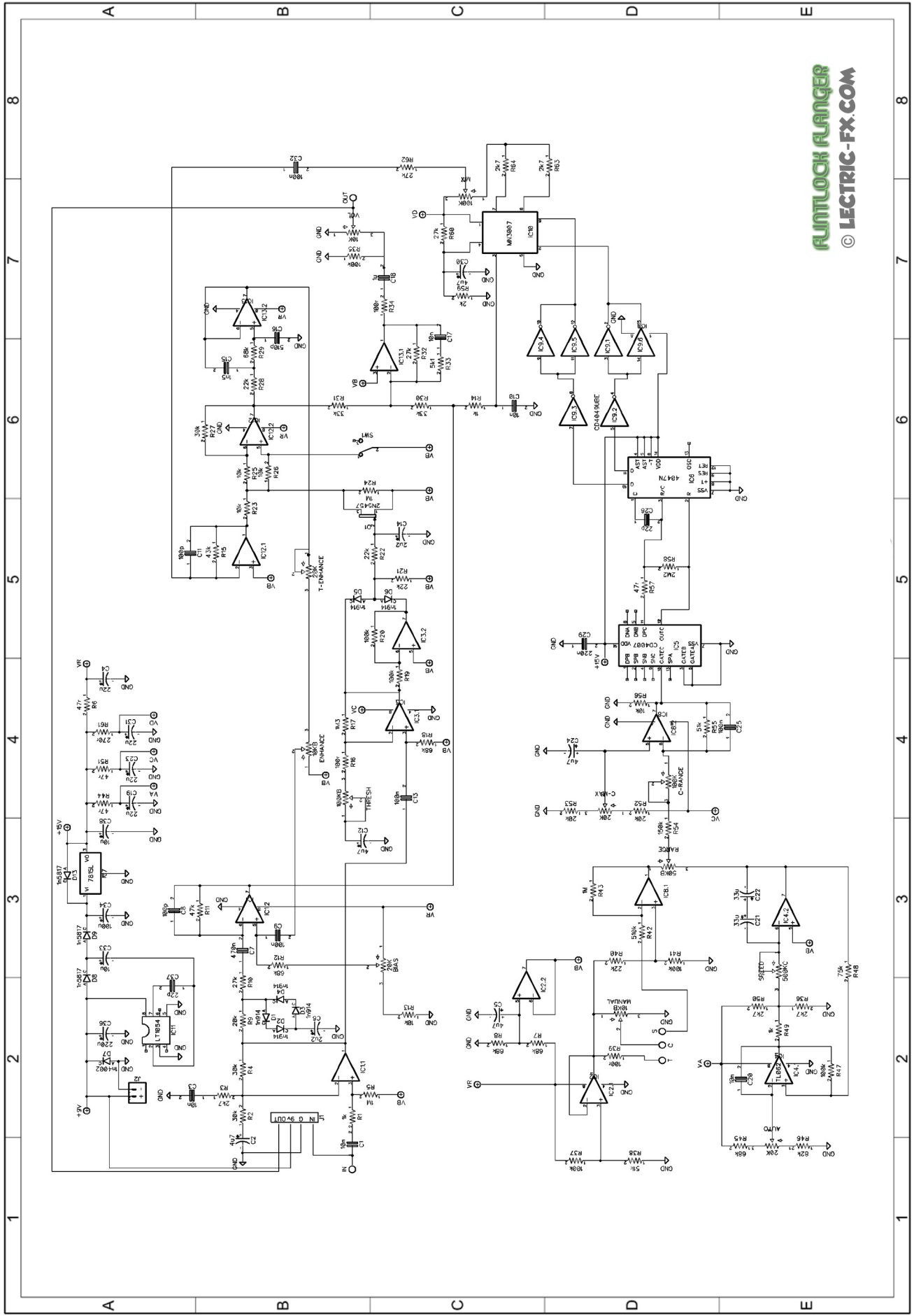

OK first off, install your jumpers. I recommend building this with an MN3007 (image on left), but it is possible to build with v3207. I would leave the 3207 version to the builder who is more adventurous since it may need some tweaking and experimentation to sound best. The jumpers under IC10 will be horizontal for MN3007, vertical for v3207.

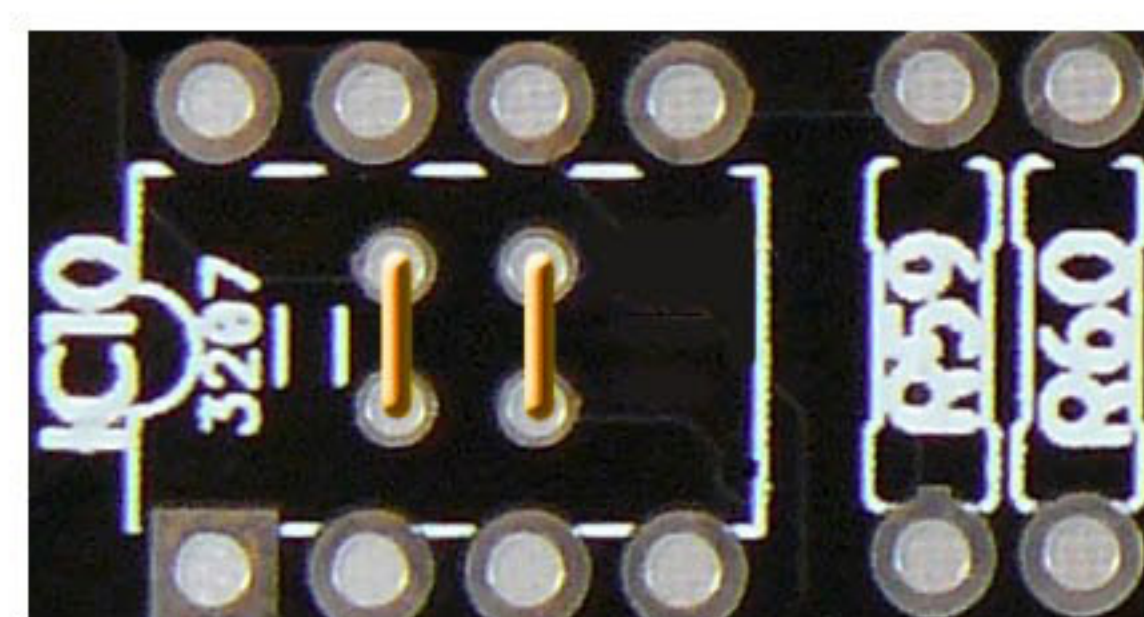
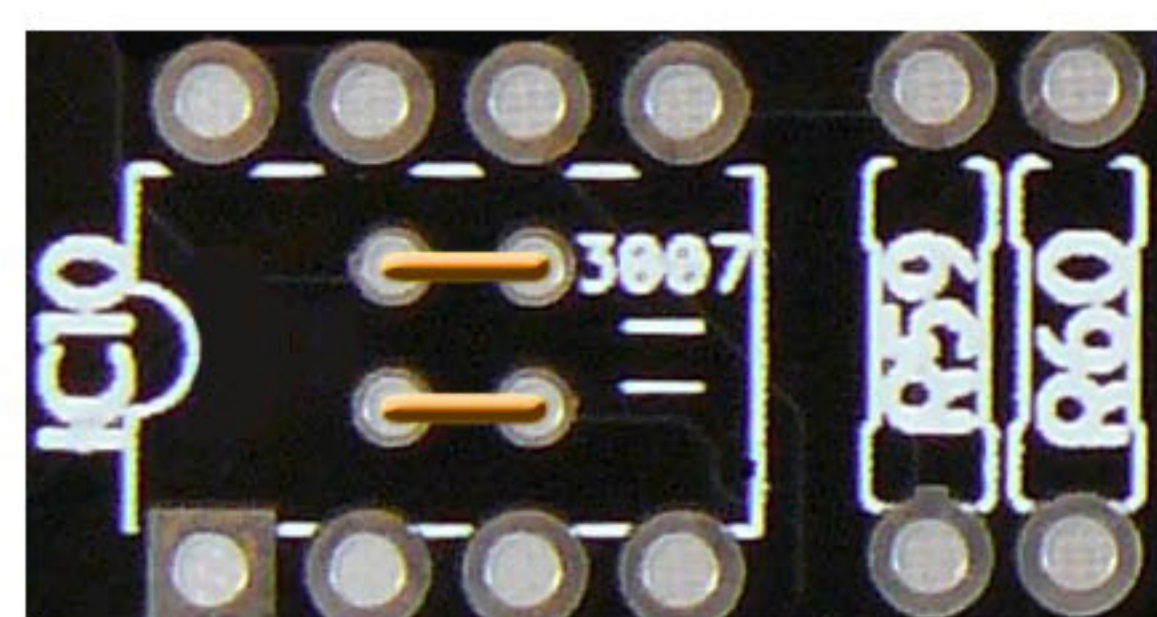

Second, you will need to install a jumper between the C & S pads as shown below, unless you are going to wire up an expression jack (which also means you need a bigger enclosure than 1590bb). If you use an expression jack it needs to be a switching jack such as Mouser pn 568-NYS218 (credit to moosapotamus).

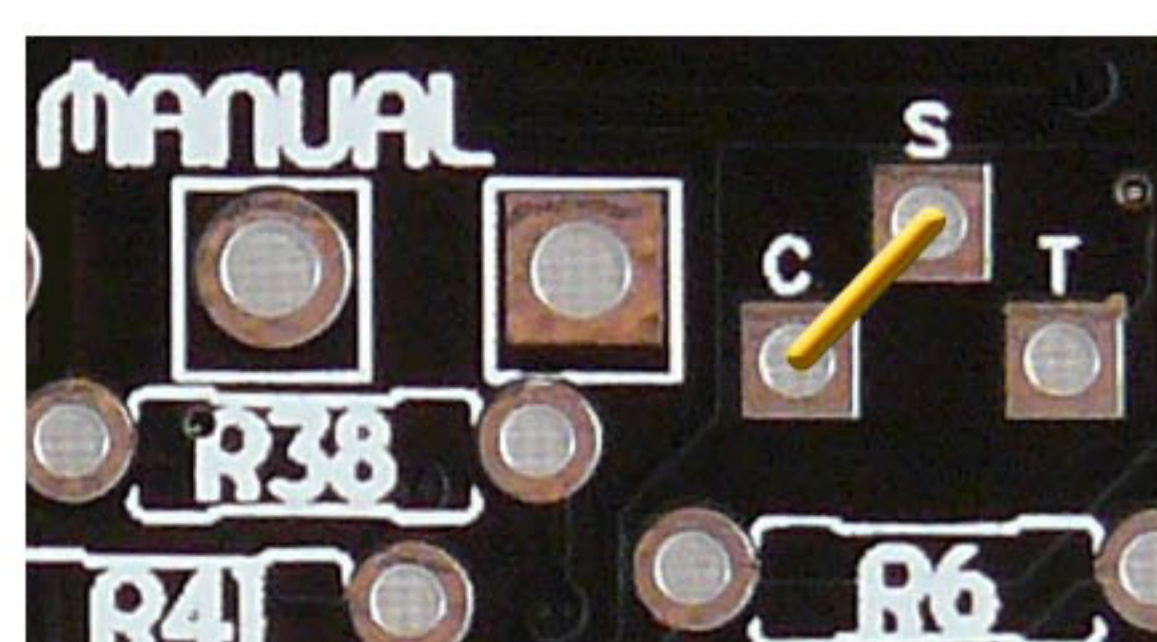

Next, I would start soldering in components according to height. Jumpers were first, next you could do your 1n914's, then resistors, then the larger diodes. Then your 3362 type trimmers, followed by sockets, then on to transistors, ceramic and box caps. Finally install your electrolytic caps and you should be just about finished. Install your ic's and wire everything up. Time to move on to calibration.

Basic set up procedure - 3007 version using a frequency counter (suggested);

Set all trimmers to 50% and all pots fully CW (The ODD/EVEN switch position during this procedure is not important).

First, power up and test for 15V at the test pad provided, then move on if it tests okay..

Start turning the bias trimmer until you hear a the modulated signal kick in to confirm you have signal through the pedal and that your clock and BBD are functioning and set the volume trimmer to an acceptable level to revisit later.

Now set the range & manual pots fully CCW and set your multimeter to the frequency setting (Hz) put the red probe to the test pad at pin 13 of the 4047 and the black lead to ground to start setting the clock frequencies.

(If you are not using a frequency counter see below)

Begin adjusting the 'C-Max' trimmer until you measure 69.6KHz, then turn the manual pot fully CW and adjust 'C-Range' until your meter reads 2.6Mhz and repeat, both trimmers interact and are very sensitive so you will likely find you have to repeat this process a few times until the manual pot sweeps between 69.6KHz & 2.6MHz.

Basic setup Procedure (Cont'd)

Once you have the clock frequencies set correctly, continue measuring at the test point and now set the range pot fully CW and speed pot fully CCW, the frequency should sweep between 69.6KHz & 2.6MHz, if not, adjust the 'Auto' trim until it does.

Good job, now take a break! Setting the clock frequency is probably the most important aspect of the sound and the most time-consuming part of setting up the A/DA (Flintlock).

Getting back after your break it is now time to set up the audio part of the flintlock;

Keep all the pots set fully CW but now set the speed to where you can hear the pedal sweeping clearly (do not worry if the flange sound is distorted or weak at this point).

Input some form of signal through the pedal (either constantly playing your guitar or other signal source) and set the volume trimmer so that the bypass level matches the effect and begin to carefully adjust the bias trimmer, set it for the 'cleanest' flanged sound you can.

Now adjust the 'Mix' Trim, this sets the Wet & Dry signal mix of the pedal, the aim is to set the wet (flanged) signal equal with the dry for a 50/50 mix, this will provide the 'best' flanger sound.

Finally you can set the 'Enhance' Trimmer, this is a matter of personal taste, you can adjust it so that the pedal will self oscillate with the Enhance pot set fully CW or to just before the point of self oscillation. Keep in mind that allowing the enhance pot to reach self oscillation can lead to some interesting experimental sounds when used in conjunction with the Threshold pot to gate off the signal.

*If you intend to try and set up the clock frequencies by ear and not use a frequency counter you will not get the best the flintlock can offer but can still achieve a very nice sound.

Follow the basic premise of the frequency counter set up above and set the low frequency (longer delay) to a point where no clock whine is heard and the high frequency to where you feel is best, once you have completed the set up procedure you may wish to revisit the clock trimmers to get the widest sweep you can with the range set full, remembering though that setting the bottom of the sweep lower will result in a wider sweep but the sound may become too 'bouncy', clock whine may enter the signal and you will no longer reach the high sweep point the A/DA is famous for but that setting it too high can lead to a weak flanger sound and a smaller sweep.

When set by ear the 'Auto' trim is probably best left near the center position, adjusting it too far can lead to a lopsided sounding sweep.

A word on enclosure choice for the Flintlock Flanger

It is possible to build this effect into a 1590bb. I have successfully done it with the kind of jacks you'd use in a baby build (1590a) pedal. I do not know if standard sized jacks will fit. If you want to install an expression jack, or have your dc/in/out jacks top-mounted, you will need to jump up to a 125bb or similar (untested). Another great option would be 1590Q, which is the same size as a landscape 1590BB on all sides.

Drill Template

1590BB

Please measure very carefully. This is only a rough guideline based on what i think will work, based on what worked for me. You are ultimately responsible for ensuring a good fit on your personal build.

The I/O jacks may be a tight squeeze, and it could be wise to use the kind of jacks you would find on a “baby build”.

