

Altered State Phaser

Based on the Maestro PS1-A

Lectric-fx 05/16/2022 rev. 1.1

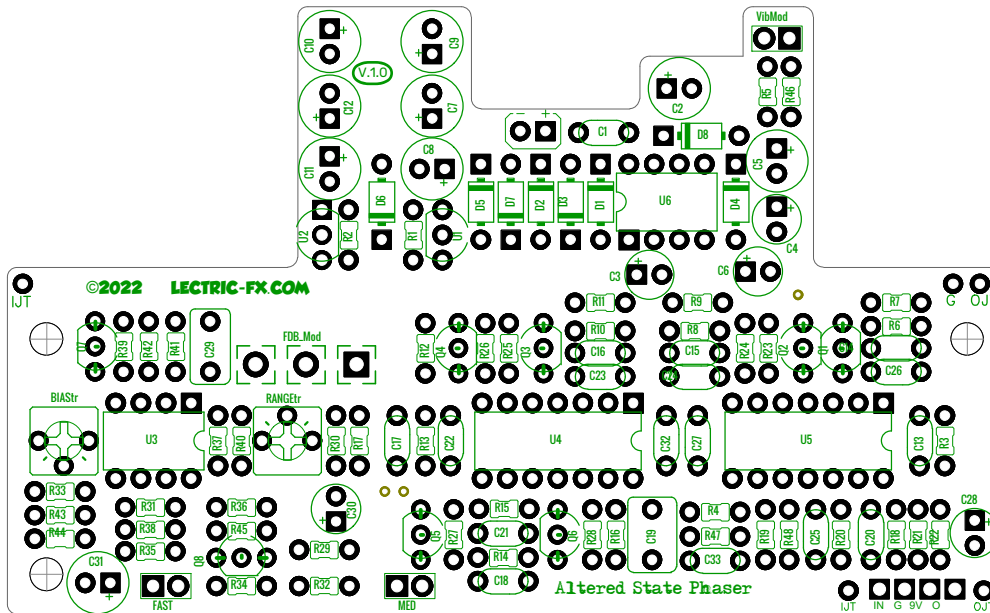

The Altered State is Lectric FX's take on the revered Maestro PS1-A Phaser. Besides shrinking the circuit down enough to fit a 1590BB enclosure, we've also converted it to run from a standard 9V DC supply, while still providing internal +/-12V supply of the original without the need for expensive specialty power bricks. We've also added a few updates for the modern player.

The transistor input buffer of the original has been replaced with an op amp buffer, delivering the same frequency response but with an increase in input impedance, just high enough to prevent the worst of the high end roll off but still retain a warm sound. Besides the improved input impedance, this has also allowed us to add a feedback control to add some new sounds and increased phase depth to the circuit (this can be omitted if desired to remain in keeping with the original circuit, see build notes).

The output FET switching is also removed to make way for modern true bypassing and a buffered op amp output, simultaneously removing the need for adjusting the offset voltage of the final all pass stage and preventing any signal loss.

Additionally, we've added the option of a pitch vibrato switch modification. Vibe works best when feedback pot (optional) is fully rolled off, and will be most apparent in the fast mode, so please keep that in mind if you choose to use it.

Op Amp Choice

The original circuit used 1458 op-amps throughout, here we've opted for quad op-amps in the audio path. We strongly recommend the TL074 for the Altered State, the background noise level is substantially reduced and due to its improved internal compensation, even the propensity of the circuit to tick is reduced.

If you however wish to stay in keeping with the original, the LM348 would be the chip to go with.

The LFO op-amp (U3) should remain an 1458 type and has no impact on hiss levels.

J-FET Choice

The original circuit called for 2N4303 J-FET's, these are no longer easy to come by so we recommend the 2N5485 (available to purchase in pre-matched sets through the Lectric FX store) as a suitable alternative.

2N5457 will also work well enough.

Q1 - 6 Must be matched for Vgs(off) to produce proper phasing effect.

Set Up Procedure

Two trims are found on the board, Bias & Range, these are used to match the LFO circuit to the particular FET's you're using, due to their highly variable production nature.

Feedback should be set full CCW and Vibrato turned off while setting up.

The original biasing procedure is given as such;

"1. FET Bias - With range trim fully off (no moving phase heard), adjust FET bias so that audible phasing sound is in the middle of its range. 2. Range Trim - Adjust for desired depth of phasing sound"

This can take some experimenting to get dialed in and the trimmer effects are interactive, it can help to think of the bias as a symmetry control and the range as a fine tuning to prevent overshoot in the sweep (which leads to ticking, white noise and various other unpleasant artifacts when not dialed in correctly) we suggest if possible watching a couple of online demos while setting up to get a feel for how the circuit should sound.

Feedback Mod

If you wish to omit the feedback pot mod, simply omit R47, C32 and the Feedback pot itself.

Vibrato Mod

If you wish to omit the vibrato switch mod, simply jumper the two switch pads.

B.O.M.

1/8W RESISTORS	
R1	33R
R2	33R
R3	47k
R4	100k
R5	100k
R6	100k
R7	100k
R8	100k
R9	100k
R10	100k
R11	100k
R12	100k
R13	100k
R14	100k
R15	100k
R16	100k
R17	47k
R18	47k
R19	100k
R20	1M
R21	470k
R22	100k
R23	100k
R24	100k
R25	100k
R26	100k
R27	100k
R28	100k
R29	10k
R30	33k
R31	33k
R32	82k
R33	10k
R34	3k9

R35	1M
R36	4k7
R37	10k
R38	33k
R39	10k
R40	75k
R41	150k
R42	10k
R43	180k
R44	10k
R45	1M
R46	2M2
R47	200k
R48	75k
CAPS	
C1	100n
C2	100u
C3	10u
C4	10u
C5	100u
C6	10u
C7	100u
C8	100u
C9	100u
C10	100u
C11	100u
C12	100u
C13	10p
C14	47p
C15	47p
C16	47p
C17	47p
C18	47p
C19	1u film
C20	10p

C21	10n
C22	10n
C23	10n
C24	10n
C25	100n
C26	10n
C27	10n
C28	4u7
C29	330n
C30	4u7
C31	220u
C32	10n
C33	680p
DIODES	
D1	1n4002
D2 -D8	1n5817
TRANSISTORS	
Q1-Q6, Q8	2N5485
Q7	2N3906
IC's	
U1 (+12V reg)	LM78L12
U2 (-12V reg)	LM79L12
U3	LM1458
U4	TL074
U5	TL074
U6	LT1054
SWITCHES	
SLOW	3PDT
MED, FAST	DPDT OR > **
Vibrato Mod *	SPST or SPDT
POTS	
FDB Mod *	100KA
TRIMMERS	
RANGEtr	10K
BIAStr	10K

*Optional mod.

**Must be 3PDT if using included daughter boards, but can be hand wired with DPDT (w LED indicator) or even SPST (w/o LED)
You should be able to use 2n5457 for Q8.

QTY's

RESISTORS	
2	33R
1	3k9
1	4k7
6	10k
3	33k
3	47k
2	75k
1	82k
21	100k
1	150k
1	180k
1	200k
1	470k
3	1M
1	2M2
3	CLR for LED's

CAPS	
2	10p
1	680p
5	47p
7	10n
2	100n
1	330n
1	1u Film
2	4u7
3	10u
8	100u
1	220u

DIODES	
1	1n4002
7	1n5817
TRANSISTORS	
1	2N3906
7	2N5485
IC's	
1	LM78L12
1	LM79L12
1	LM1458
2	TL074
1	LT1054
SWITCHES	
2	DPDT or >
1	SPST
POTS	
1	100KA
TRIMMERS	
2	10K tr

Note: there are 2 or 3 mounting holes provided on the pcb that might come in handy if the feedback pot mod is left off of your build, so that the main pcb isn't left "floating." The inner diameter is approximately 3.5mm. These work well with 11mm adhesive-backed standoffs such as Tayda part A-2882 or similar.

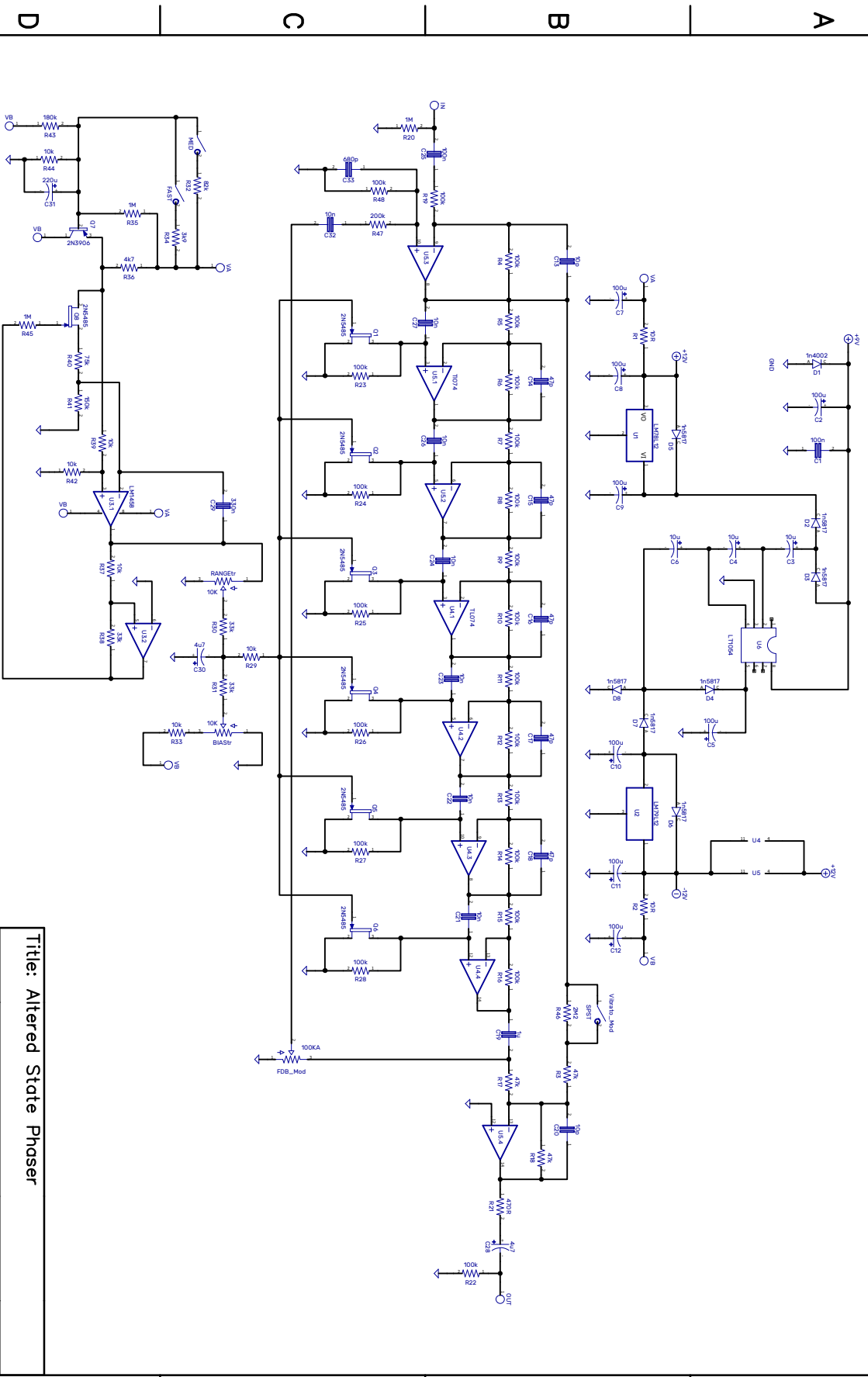

Title: Altered State Phaser

Size	Number	Rev
000001		10

Date: 04/30/2022

Drawn by Haberdasher

Filename

Sheet 1 of 1

1 2 3 4 5 6

WIRING SUGGESTION

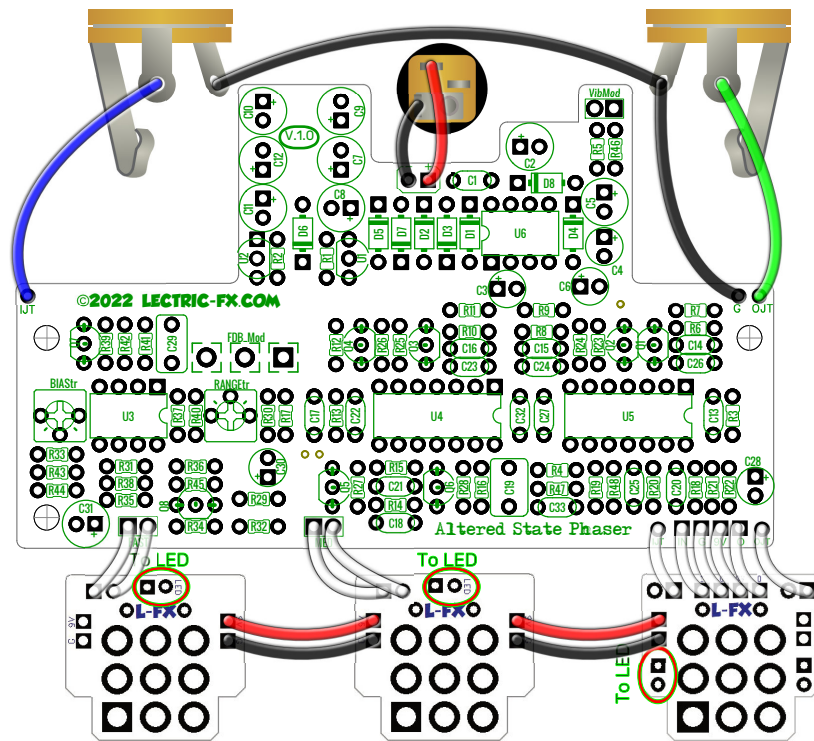

Don't forget to Place 3 CLR's onto the small 3pdt pcb's where the L-FX logo appears.

DRILLING SUGGESTION

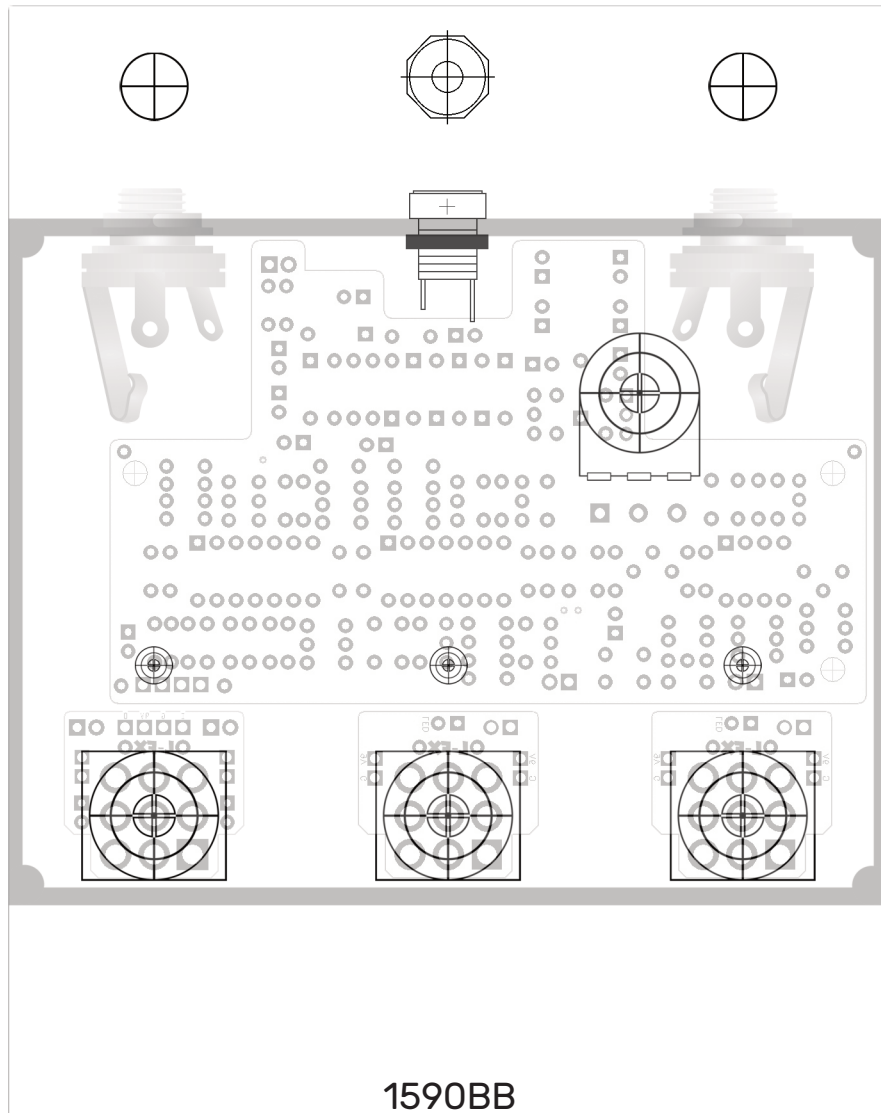

Location for vibe switch mod not shown, as it is left up to the builder. The pot location for the feedback mod is where a pc mounted type would be, but a lug pot can be wired and placed wherever you want it. LED locations are only suggestions, but of course they can be wherever you want as well.